

Masport®

ROTARY MOWERS

SERIES 18

Part Number

565811

Model

350 ST SP 19

Engine

B&S 500E

Month and Year of Manufacture: January 2020

Starting Serial Number: 8430197



Issue A.0
ECN 04160
Feb 2020 PB
REF # 765811S



460mm Disc Blade- Flat, Assembly

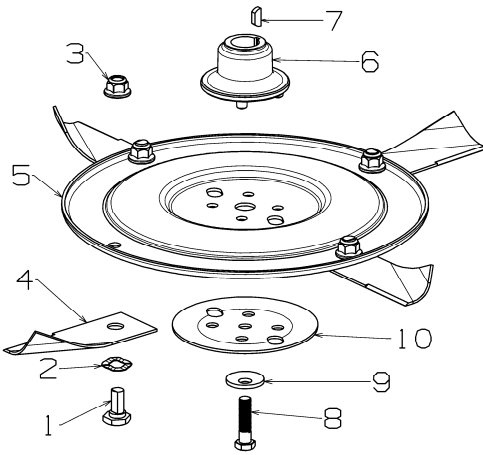

Item	Part No	Description	Qty
1	581707	Bolt- Pivot M10 x 22	4
2	580693	Washer, Wavy 13.4 x 24.2	4
3	503672	Nut, M10 Hex Nyloc Flange	4
4	529150	Blade- Swing Back, 460mm	4
5	980082	Disc Blade- Flat	1
6	567143	Driver- Blade, 22mm dia	1
7	500636	Key, Woodruff, 5/8 x 5/32 x 1/4	1
8	503543	Bolt; Hex NF 3/8 x 1.5 NYG8	1
9	502297	Washer- Belleville 10 x 30 x 3	1
10	567332	Plate- Stiffener, Disc Blade Assy	1

Blade (Flat) & Bolt Sets

- 783692 Bolt Set (4)**
Includes Items: 4 x **1, 2, 3**
- 729150 Blade- Swing Back, 460 (4per)**
Includes Items: 4 x **1, 2, 3, 4**
- 980550 Disc Assy- Flat (4 Blade) 460mm**
Includes Items: **1, 2, 3, 4, 5, 10**

767058 Catcher Assembly 18"

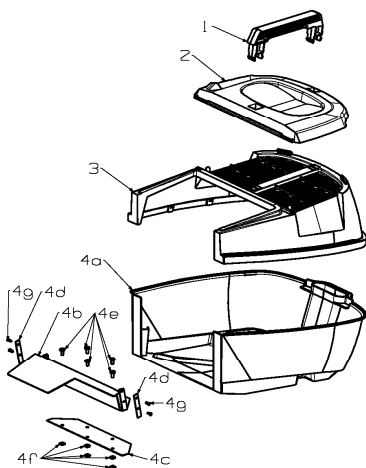

Item	Part No	Description	Qty
1	580673	Handle- Catcher	1
2	580674	Lid- Catcher	1
3	579117	Top- Catcher	1
4a	567057	Catcher- Bottom, 18" SP Brand/Grey	1
4b	573133	Lip- Catcher, 18" Tunnel	1
4c	582222	Lip- Catcher, Backing Plate	1
4d	982223	Plate- Rivet, Catcher Backing	2
4e	503591	Screw, Pan M6 x 12	5
4f	502098	Nut, M6 Square, Pressed	5
4g	501303	Rivet- Pop 4.0 x 7.9 73AS5-5	4

When ordering spares: PLEASE QUOTE PART NUMBER & Description, NOT illustrated number. Item Qty = 1 per part unless stated differently. **BOLD TEXT** = Assemblies. Text starting with * = items included in the assemblies & may not be available as a spares item. Determine the left hand or right hand sides by standing in the operating position (standing at the handle).

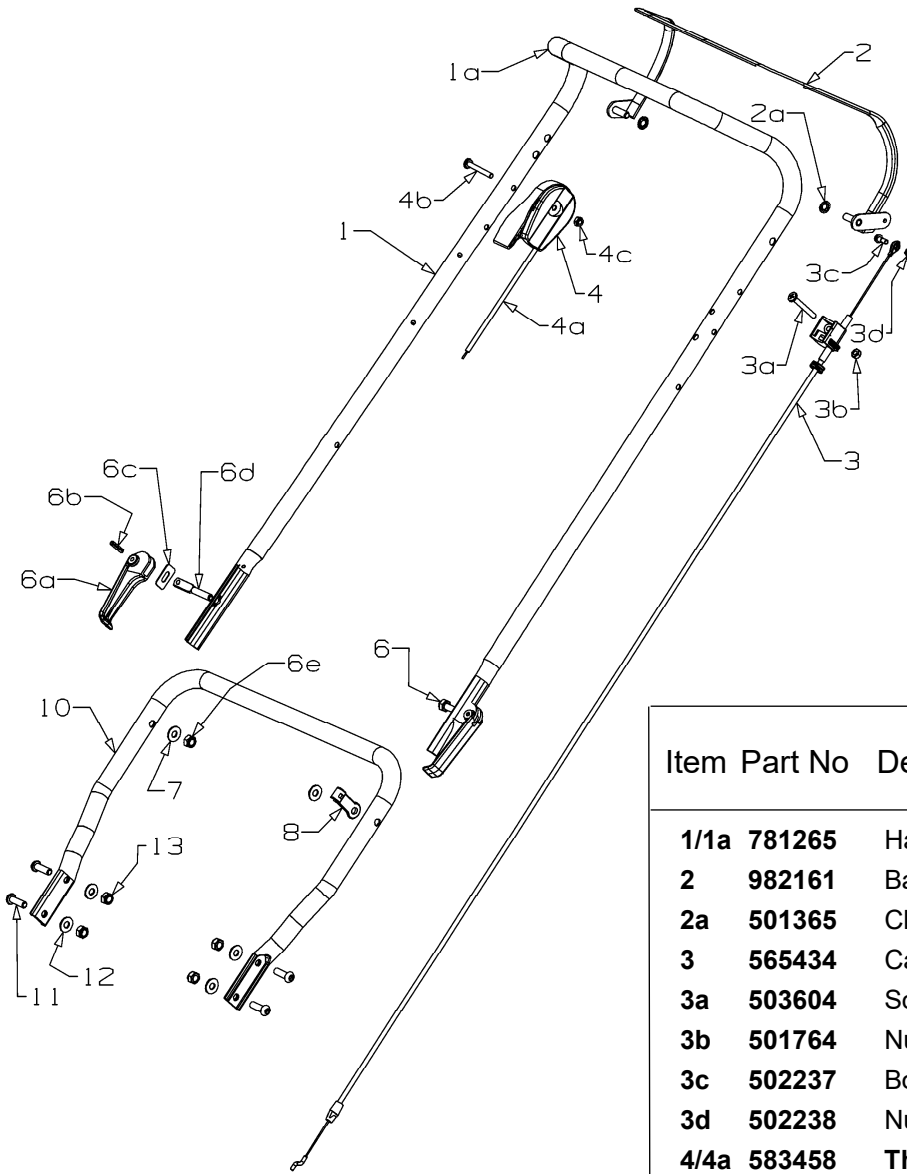

Item	Part No	Description	Qty
1/1a	781265	Handle & Sleeve	PVC/CHR 1
2	982161	Bail Arm Assy, SP	1
2a	501365	Clip Starlock 5/16"	2
3	565434	Cable- Clutch, Thumbwheel	1
3a	503604	Screw, Pan M6 x 45 Poz ZP	1
3b	501764	Nut, M6 Hex Nyloc x 6mm thick	1
3c	502237	Bolt, Hex Flat/Head Shouldered	1
3d	502238	Nut, M5 Hex Nyloc x 5mm thick	1
4/4a	583458	Throttle Ctrl & Cable, Wescon	1
4b	503604	*Screw, Pan M6 x 45 Poz ZP	1
4c	501764	*Nut, M6 Hex Nyloc x 6mm thick	1
6	779755	Cam Lock Assy (1 per)	2
6a	582419	*Lever- Handle Locking	1
6b	503369	*Pin- Tension 5.0 x 22	1
6c	016777	*Washer, Slipper S/S	1
6d	583041	*Stud- Handle Lock, 61mm	1
6e	501793	*Nut, M8 Hex Nyloc x 8mm thick	1
7	501606	Washer, Flat 8 x 19 x 1.6	2
8	581527	Retainer- Clutch Cable	1
10	981257	Handle- Lower, "U" 18"	1
11	503643	Screw, Set M8 x 25 Btn/Head	4
12	501606	Washer, Flat 8 x 19 x 1.6	4
13	501793	Nut, M8 Hex Nyloc x 8mm thick	4

Not Illustrated

503054	Tie- Nylon Cable, Black	4
568665	Decal, HSG Easy Drive	1
573152	Decal, Noise S18 300 96db	1
573275	Decal, HSG S18 350	1
581180	Catcher Assy Instructions	1
582049	Decal, Flap Caution	1
582062	Decal, Height Combo	1
582070	Decal, Serial Number	1
583152	Owner Manual, Masport	1

When ordering spares: PLEASE QUOTE PART NUMBER & Description, NOT illustrated number. Item Qty = 1 per part unless stated differently. **BOLD TEXT** = Assemblies. Text starting with * = items included in the assemblies & may not be available as a spares item. Determine the left hand or right hand sides by standing in the operating position (standing at the handle).

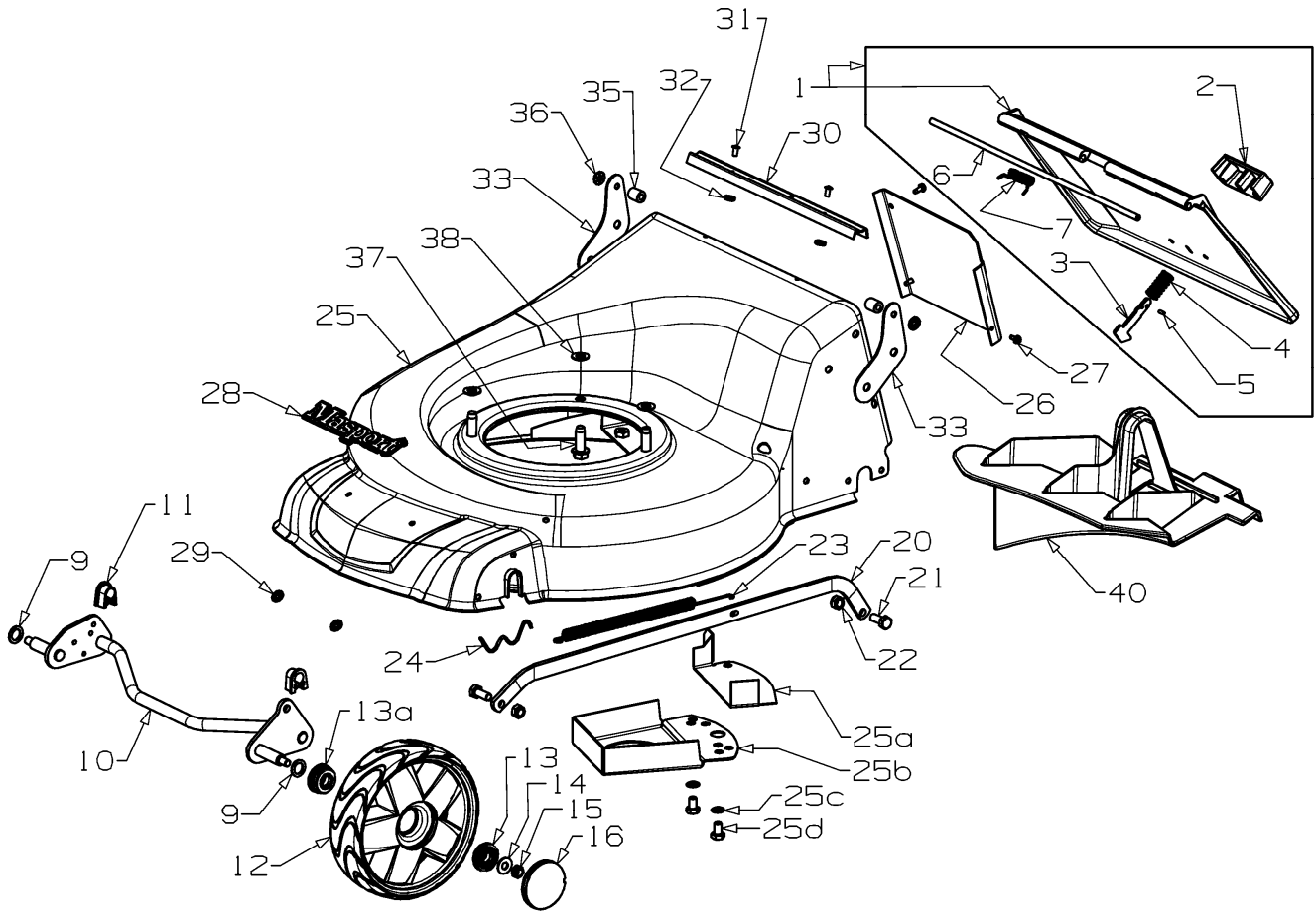

Item	Part No	Description	Qty	Item	Part No	Description	Qty
1	764242	Flap Assy- Plastic, Latched	1	24	529674	Retainer-Axle W, Front	2
2	580602	*Handle - Flap	1	25	764123	Housing- Stl T 18" XFQ SP TTNM	1
3	981650	*Latch- Flap, Barbed	1	25a	565280	*Cover- Belt, SP 18" Stl Syncro	1
4	581106	*Spring- Latch, Flap	1	25b	567412	*Cover- Belt, SP 21" Syncro	1
5	502019	*Pin, Tension 3.0 x 8	1	25c	503747	*Washer, Spg 8	2
6	779732	*Wire-Flap Pivot 6mm x 377mm	1	25d	501863	*Screw, Set M8 x 12 Hex	2
7	581349	*Spring-Flap ST Deck	1	26	573131	*Tunnel- G/Box Cover 18" ST	1
9	503301	Washer; Flat 1/2 x 3/4 x 18g	2	27	503630	*Screw, S/T 10 x 0.4	3
10	565495	Axle- Front, 18" SP	1	28	581240	Nameplate MASPORT	1
11	580030	Bush- Pivot, Front Axle	2	29	503150	Clip-Starlock, 5 dia	2
12	579196	Wheel Assy-175mm Spkd Silver (Includes 2 x 551212 per wheel)	2	30	583151	Dust Seal- Flap	1
13	551212	Bearing- Wheel, Ball	2	31	581369	Rivet- Pop 4.0 x 3.2 73SS5-2	2
13a	579694	Bearing- Wheel	2	32	502170	Washer, Nylon 5 x 12 x 2.0	2
14	501606	Washer, Flat 8 x 19 x 1.6	2	33	567585	Bracket- Flap, Black	2
15	503831	Nut, M8 Hex Nyloc x 6mm thick	2	35	579733	Spacer- Flap	2
16	579198	Hub Cap, Button, Spoked Silver	2	36	503574	Clip- Starlock, 6mm dia	2
20	567574	Rod- Connecting, 18" SP	1	37	580453	Screw, S/T 3/ 8" x 1-1/8"	3
21	501597	Screw, Set M8 x 20 Hex	2	38	501704	Washer, Flat 10 x 19 x 1.6	3
22	501793	Nut, M8 Hex Nyloc x 8mm thick	2	40	573278	Insert- Mulching, 18" T STL SP	1
23	581463	Spring-Counter Balance, Non-SP	1				

When ordering spares: PLEASE QUOTE PART NUMBER & Description, NOT illustrated number. Item Qty = 1 per part unless stated differently. **BOLD TEXT** = Assemblies. Text starting with * = items included in the assemblies & may not be available as a spares item. Determine the left hand or right hand sides by standing in the operating position (standing at the handle).

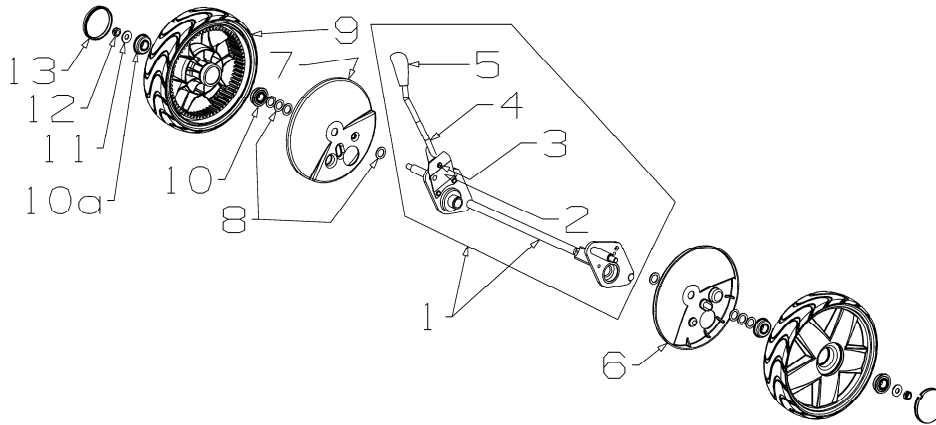

Item	Part No	Description	Qty	Item	Part No	Description	Qty
1	765496	Axle Assy Rear Drive, 18"SP	1	9	567568	Wheel Assy-200mm SP, Spkd Sil	2
2	580649	*Spring Leaf	1			(Includes 2 x 551212 per wheel)	
3	503373	*Rivet- F/HD 3/16" x 27/64"	3	10	579694	Bearing Wheel Plastic	2
4	973681	*Rod-Height Selector (MSV) ZP	1	10a	551212	Bearing-Wheel,	2
5	581729	*Knob- Height Lever, MSV Black	1	11	501606	Washer, Flat 8 x 19 x 1.6	2
6	567597	Cover Dust RH + LH 250 ST SP	1	12	503831	Nut, M8 Hex Nyloc x 6mm thick	2
7	567597	Cover Dust RH + LH 250 ST SP	1	13	579198	Hub Cap-Button Spoked Silver	2
8	503301	Washer; Flat 1/2 x 3/4 x 18G	8				

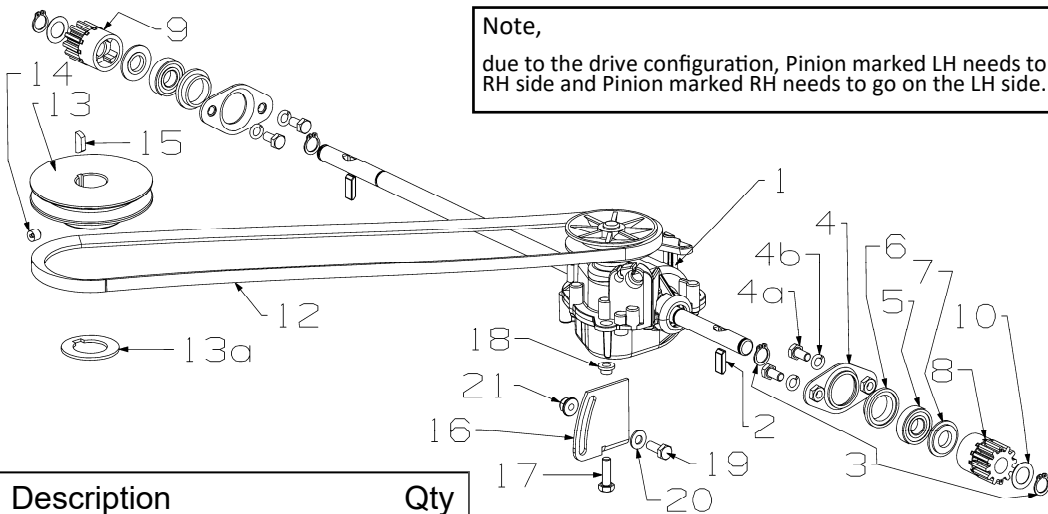

Note,
due to the drive configuration, Pinion marked LH needs to go on the RH side and Pinion marked RH needs to go on the LH side.

Item	Part No	Description	Qty	Item	Part No	Description	Qty
1	567358	Gearbox- Single SP Synchro	1	12	573810	Belt-V No.6731 3L-787 Gates	1
2	581092	Pawl Pinion, 950SP	2	13	564136	Pulley-Engine, 7/8"b x 89d x 28h	1
3	503759	Circlip, 12EXT DIN 471	4	13a	569552	Spacer- Pulley, 25x42x2 (If required)	1
4	568601	Retainer Axle Rear 18" ST SP	2	14	503386	Screw, Grub M8 x 8	1
4a	501959	Screw, Set M6 x 12	4	15	500636	Key-W/Ruff 5/8 x 5/32 x 1/4	1
4b	500201	Washer, SPG 6	4	16	557459	Mount-Gearbox 18" ST SP	1
5	503901	Bearing, Ball 12 x 28 x 8 6001-2RSH	2	17	501600	Screw, Set M6 x 20	1
6	568600	Bush- Pivot, Rear Axle	2	18	564093	Bush-G/Box Mount, ST Synchro	1
7	568603	Cap- Pinion, SP	2	19	501702	Screw, Set M6 x 16	1
8	569179	Pinion - R/H,12 Teeth	1	20	501703	Washer, Flat 6 x 14 x 1.2	1
9	569178	Pinion - L/H,12 Teeth	1	21	503973	Nut, M6 Hex Nyloc Flanged	1
10	503102	Washer, Flat 12 x 20 x 0.4	2				

When ordering spares: PLEASE QUOTE PART NUMBER & Description, NOT illustrated number. Item Qty = 1 per part unless stated differently.
BOLD TEXT = Assemblies. Text starting with * = items included in the assemblies & may not be available as a spares item.
 Determine the left hand or right hand sides by standing in the operating position (standing at the handle).