

Masport®

REEL LAWN MOWER

OPC 500 Golf Series

<u>Mower</u>	<u>Model</u>		<u>Engine</u>	<u>Shaft Dia</u>	<u>Introduction</u>	<u>Serial Number</u>
019053	500 - Golf	OPC	Intec 60 IC	19	Aug 2010	7353386
019085	500 - Golf	OPC	Intec 60 IC	19	Jan 2011	7413291
019086	500 - Golf	OPC	Honda GX160	20	Jan 2011	7411242
019087	500 - Golf	OPC	Honda GC160	20	Sep 2010	-----
019103	500 - Golf	OPC	B&S 5.0 Hp	19	Nov 2013	7781799

Upturned Handle Used On:

019085
019086
019087
019103

MSV Handle Used On:

019053



Issue C.1
ECN 02926
Jan 2015 PB
REF # 719053S



NOT ILLUSTRATED

031888	Decal, Caution S/N & Db 500	1
031891	Decal, Trans Cvr 500/660	1
031894	Decal, G/Catcher 500	1
031900	Decal, Caution, Feet & Hands	1
031992	Owner Manual, Reel Mower	1
569323	Warranty Card MASP	1
537967	Washer-Rear Axle(If required)	3
Honda Engine's require		
503630	Screw,S/T 10x.4	2
503950	Deflector-Honda Engine	1
Honda -Throttle Cable Routing Change TB129		
503489	Screw, Set M5 x 16	1
550500	Clamp- Cable, Throttle Adapter	1

731969
Catcher Assy, 500 Green 1



OPC Safety Cut Out Assy

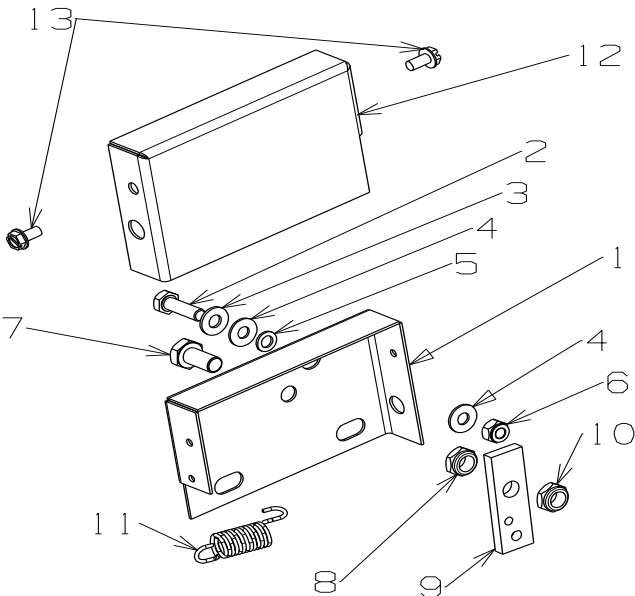

Item No	Part No	Description	Qty
1	031880	Safety Switch Housing	1
2	501600	Screw,Set M6x16 Hex	1
3	501703	Washer,Fit M6x14x1.2	1
4	031883	Washer,Fibre M6x10x1	1
5	031884	Washer,Fibre M6x14x1	2
6	501764	Nut,M6 Nyloc x 6mm Thick	1
7	501597	Screw,Set M8x20 Hex	1
8	503831	Nut,M8 Nyloc x 6mm Thick	1
9	031885	Safety Switch Lever Arm	1
10	503831	Nut,M8 Nyloc x 6mm Thick	1
11	031886	Spring	1
12	031881	Safety Switch Cover	1
13	580540	Screw,S/TM5x10 POZ	2

NOT ILLUSTRATED

031906	Safety Switch Loom B&S	1
	(Fit spade onto item 2 prior to assembly)	
031882	Safety Switch Loom Honda	1
	(Fit spade onto item 2 prior to assembly)	



Chassis Assembly

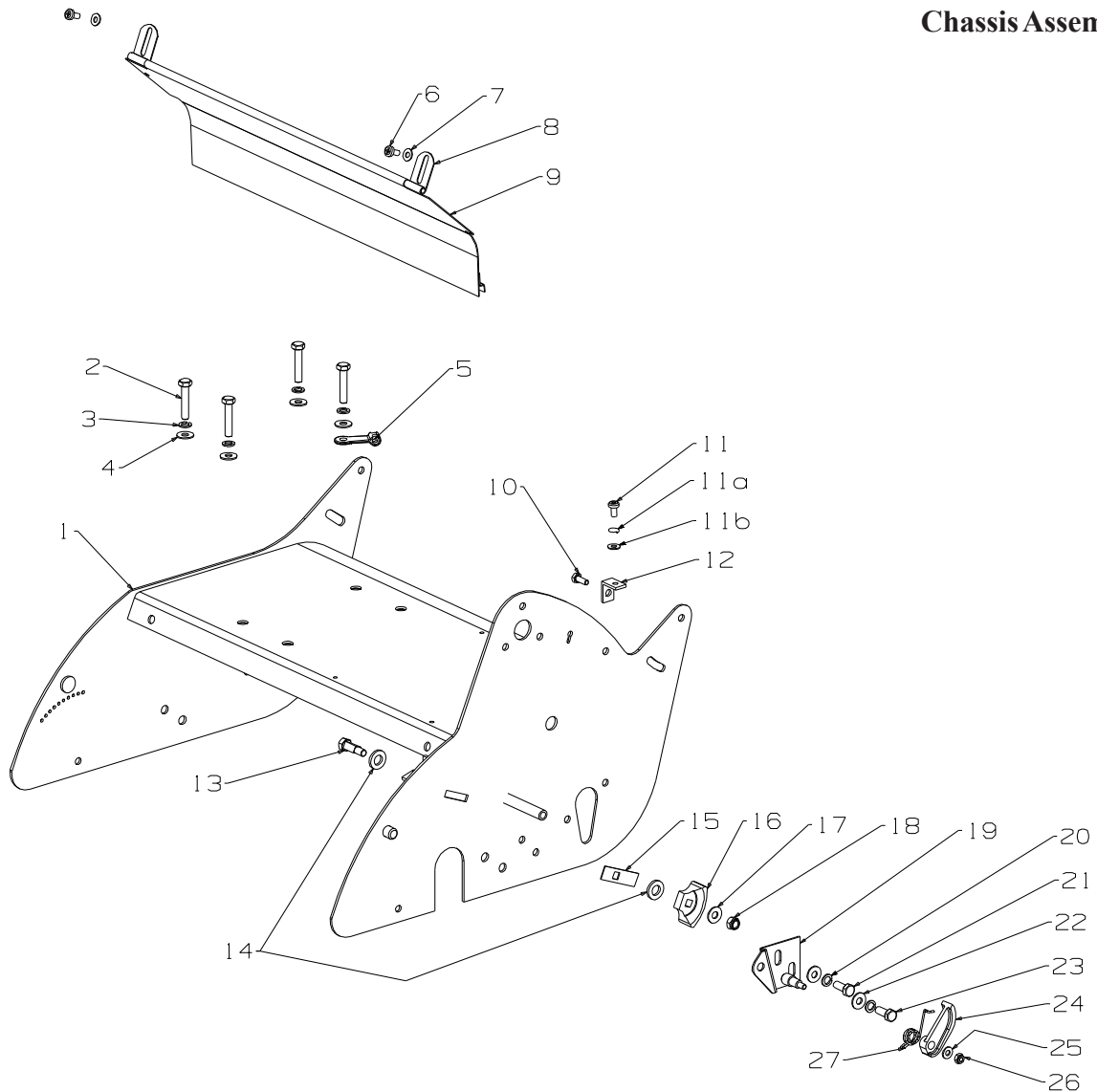

Item No	Part No	Description	Qty	Item No	Part No	Description	Qty
1	031590	Chassis Assy- 500 Green	1	14	006028	Washer, Flt 12x22x3.0	2
2	501843	Set Screw, M8x40 Hex	4	15	002845	Sealplate- Chain Adjuster	1
3	503747	Washer, Spg 8	4	16	002844	Adjuster- Chain, Fixed Nylon	1
4	501606	Washer, Flt 8x19x1.6	4	17	501606	Washer, Flt 8x19x1.6	1
5	581527	Retainer, Clutch Cable	1	18	501793	Nut, M8 Hex Nyloc 8 Thck	1
6	503591	Screw, Pan M6x12	2	19	004942	Plate Assy, Mounting	1
7	501703	Washer, Flt 6x14x1.2	2	20	503747	Washer Spg 8	2
8	002589	Bracket, Grass Chute	2	21	501571	Set Screw, M 8X 16 Hex	1
9	008901	Deflector, Grass- 500	1	22	501606	Washer, Flt 8x19x1.6	2
10	501702	Set Screw, M6x16 Hex	1	23	501571	Set Screw, M8x16 Hex	1
11	503591	Screw, Pan M6x12	1	24	004963	Adjuster- Chain, Tension Nylon	1
11a	500201	Washer, Spg 6	1	25	501703	Washer, Flt 6x14x1.2	1
11b	501703	Washer, Flt 6x14x1.2	1	26	501764	Nut, M6 Hex Nyloc 6 Thck	1
12	031915	Bracket- Chain Cover	1	27	004945	Spring	1
13	002848	Bolt- Adjuster, Chain	1				

When ordering PLEASE QUOTE PART NUMBER & Description, NOT Illustration No.
Determine right or left hand side from standing in operating position (standing at handle)
Bold Text = Assemblies, Bulleted Text * = Items included in the Assemblies

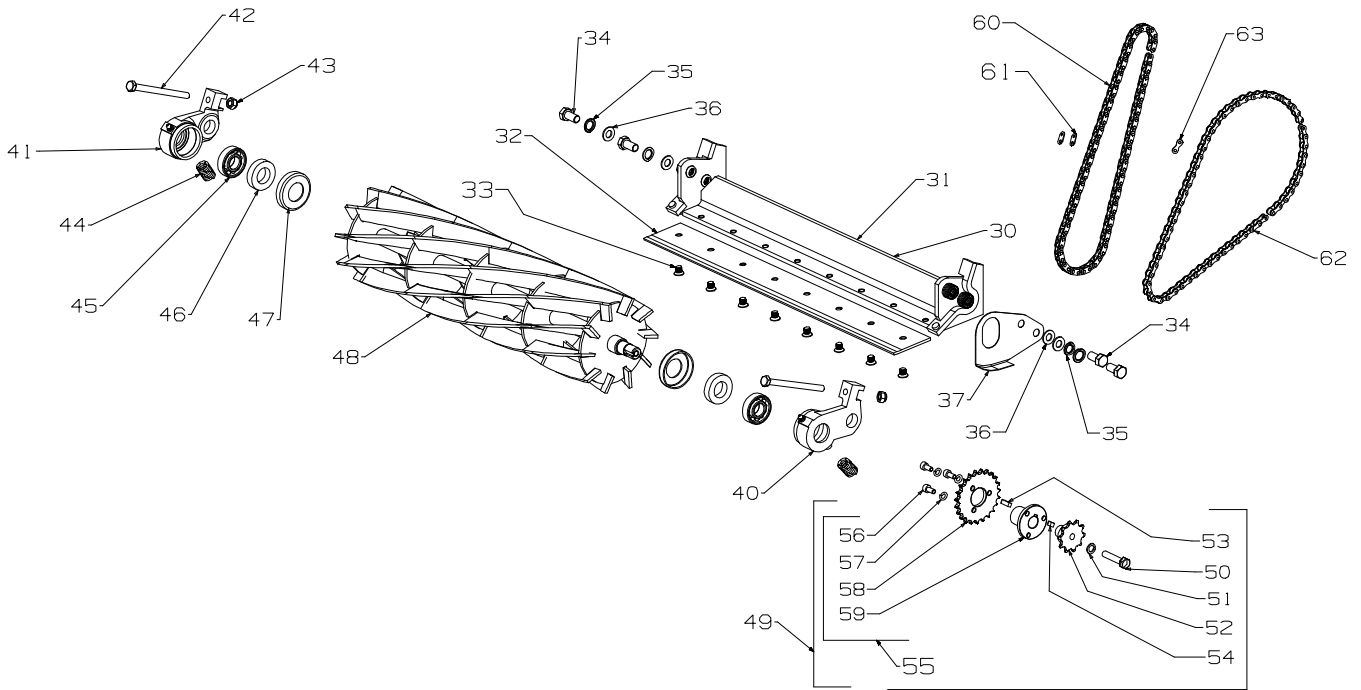

Item No	Part No	Description	Qty	Item No	Part No	Description	Qty
30	032035	Backplate Brkt, Blade Assy 500 (incl items,31,32,33)	1	52	*032002	Sproket 10T	1
31	*009862	Bracket Assy Backplate 500	1	53	*032005	Key 5x5x16	1
32	*032021	Blade- Baseplate 500, Golf	1	54	*032004	Key 5x5x10	1
33	*008611	Screw, CSK M8x10 Allen Head	8	55	*032045	Sprocket Assy - 23 Key (incl items 56,57,58 and 59)	1
34	501760	Set Screw, M10x20 Hex	4	56	*502004	Screw,Cap M6x12	3
35	503897	Washer, Spg 10	4	57	*500201	Washer, Spg 6	3
36	501704	Washer, Flt 10x19x1.6	4	58	*032003	Sprocket 23T	1
37	002561	Plate- Seal, Chaincase	1	59	*032001	Boss Sprocket Key	1
40	032023	Housing- Assy Bearing, LH	1	60	032044	Chain- 0.23xP 3/8", 76P	1
41	032024	Housing- Assy Bearing, RH	1	61	(731972)	Link- Chain 3/8"	1
42	006282	Bolt, Set NF 5/16"x4" Hex	2	62	004299	Chain- 0.205x P 1/2", 59P	1
43	007240	Nut, NF 5/16 Hex Nyloc Type "P"	2	63	(731971)	Link- Chain 1/2"	1
44	002581	Spring-Baseplate	2				
45	503273	Bearing, Ball 17x40x12 6203 2S	2				
46	002583	Seal-Felt	2				
47	005211	Cover- Dust, Cylinder Bearing	2				
48	032018	Cylinder Assy Cutting-500, Keyed	1				
49	(032006)	Sprocket Assy-10/23	1				
50	*501843	Set Screw, M8 x 40	1				
51	*503747	Washer Spg 8	1				



Front Roller Assembly - Golf

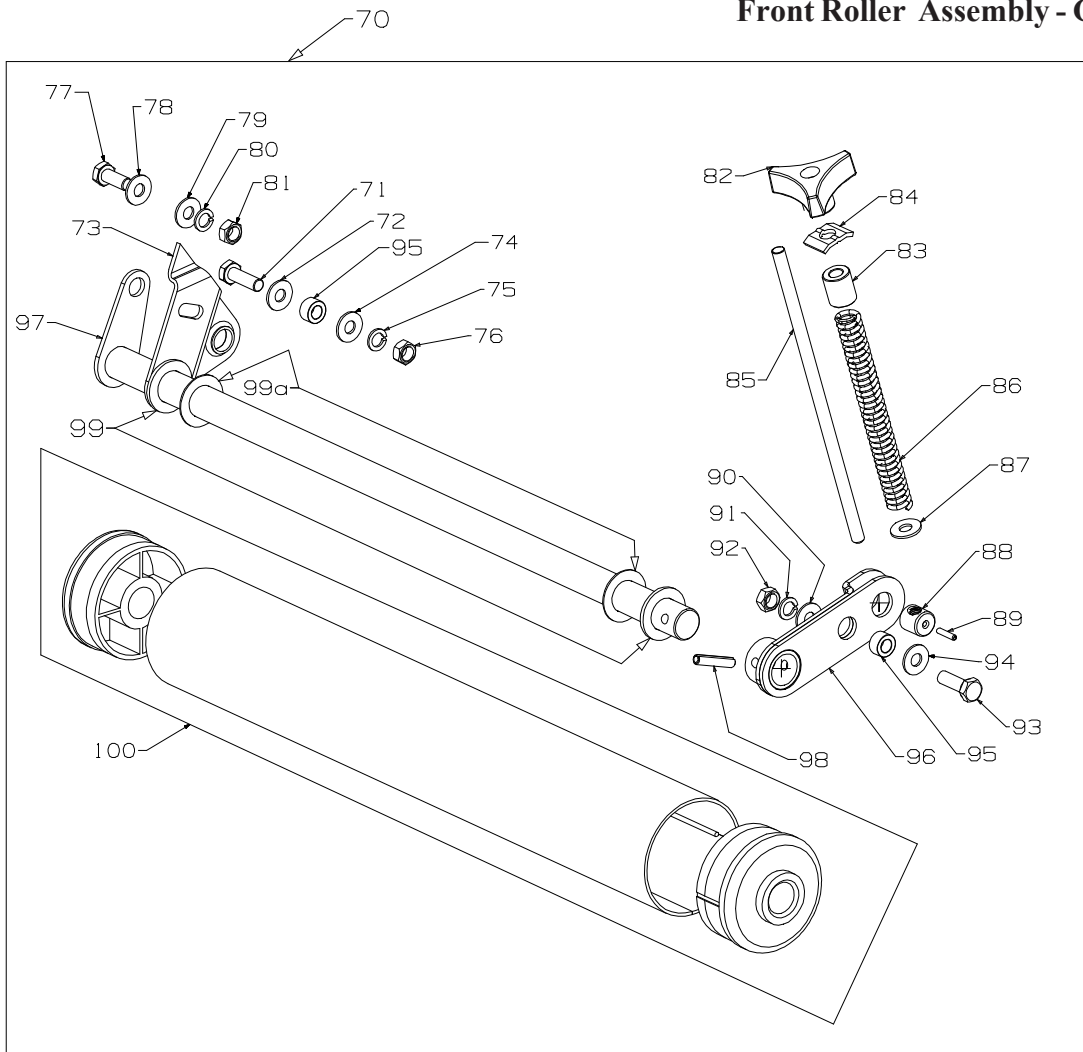

Item No	Part No	Description	Qty	Item No	Part No	Description	Qty
70	032026	Spindle & Brkt Assy Golf 500	1	87	*501606	Washer, Flt 8x19x1.6	1
71	*501598	Set Screw, M8x25 Hex	1	88	*004990	Spindle, Trunnion	1
72	*501606	Washer, Flt 8 x 19 x 1.6	1	89	*032087	Pin, Tension 3.0 x 16	1
73	*004983	Bracket- Front Roller, RH	1	90	*501606	Washer, Flt 8x19x1.6	1
74	*501606	Washer, Flt 8x19x1.6	1	91	*503747	Washer, Spg 8	1
75	*503747	Washer, Spg 8	1	92	*501602	Nut, M8 Hex	1
76	*501602	Nut, M8 Hex	1	93	*501598	Set Screw, M8x25 Hex	1
77	*501597	Set Screw, M8x20 Hex	1	94	*501606	Washer, Flt 8x19x1.6	1
78	*501606	Washer, Flt 8x19x1.6	1	95	*004991	Bush- Pivot, Front Roller	2
79	*501606	Washer, Flt 8x19x1.6	1	96	*004984	Bracket Assy- Adj, Front Roller	1
80	*503747	Washer, Spg 8	1	97	*004977	Spindle Assy Front 500	1
81	*501602	Nut, M8 Hex	1	98	*007496	Pin, Tension 6.0 x 30	1
82	*574230	Knob- Plastic, M8 Insert	1	99	*501432	Washer, Flt 20x33x4.0	2
83	*031910	Spacer- Knob	1	99a	*537967	Washer, Flt 20x33x1.0	2
84	*004973	Plate Slipper	1	100	*032029	Roller Assy-Front, 500 Golf	1
85	*004988	Spindle- Adj, Front Roller	1				
86	*004691	Spring- Height Adjust	1				



MSV Handle Assembly

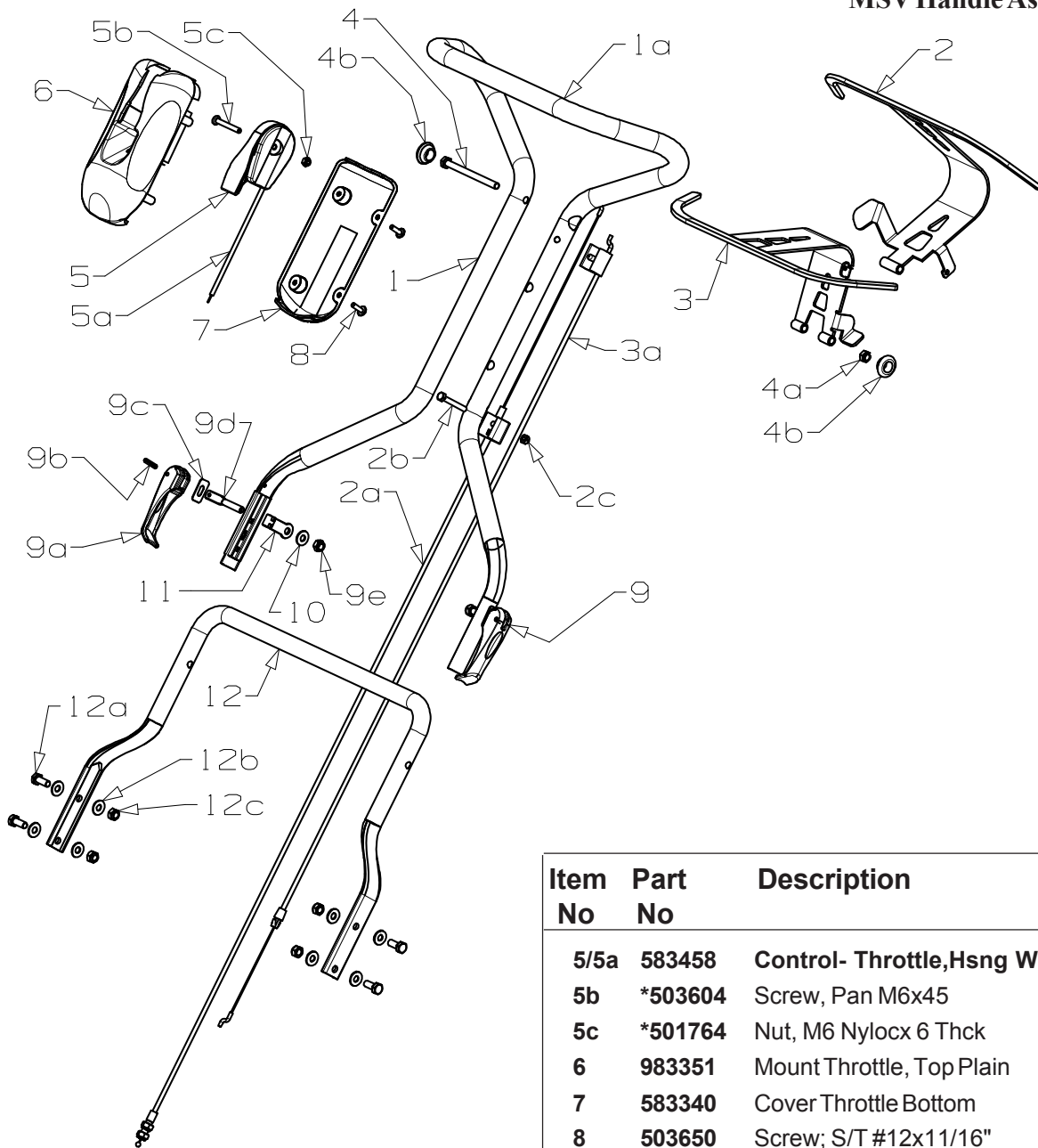

Item No	Part No	Description	Qty
1/1a	731847	Handle Upper Assembly, R/MWR	1
2	579279	Bail Arm Assy, SP MSV	1
2a	031990	Cable-Clutch, Reel Mower	1
2b	503558	Screw-Set, M6 x 45	1
2c	501764	Nut-M6 Nyloc	1
3	979278	Bail Arm Assy, OPC MSV	1
3a	581655	Cable- Eng, OPC Reel Mower	1
4	503883	Bolt Hex M8 x 100	1
4a	501793	Nut-M8 Nyloc	1
4b	503882	Grommet Blanking 3/4"(19mm)	2

Item No	Part No	Description	Qty
5/5a	583458	Control- Throttle,Hsng Wscn	1
5b	*503604	Screw, Pan M6x45	1
5c	*501764	Nut, M6 Nylocx 6 Thck	1
6	983351	Mount Throttle, Top Plain	1
7	583340	Cover Throttle Bottom	1
8	503650	Screw; S/T #12x11/16"	4
9	779755	Cam Lock Assembly	2
9a	582419	Lever- Handle, Locking	1
9b	503369	Pin, Tension 5.0 x25	1
9c	016777	Washer Slipper	1
9d	583041	Stud Handle Lock 61mm	1
9e	501793	Nut M8 Hex Nylocx Thck	1
10	501606	Washer, Flat 8x19x1.6	2
11	581527	Retainer- Clutch Cable	1
12	031849	Handle- Lower, 500	1
12a	501597	Screw, Set M8x20	4
12b	501606	Washer, Flat 8x19x1.6	8
12c	501793	Nut, M8 Nylocx 8 Thick	4

When ordering PLEASE QUOTE PART NUMBER & Description, NOT Illustration No.
Determine right or left hand side from standing in operating position (standing at handle)
Bold Text = Assemblies, **Bulleted Text** * = Items included in the Assemblies



Upturned Handle Assembly

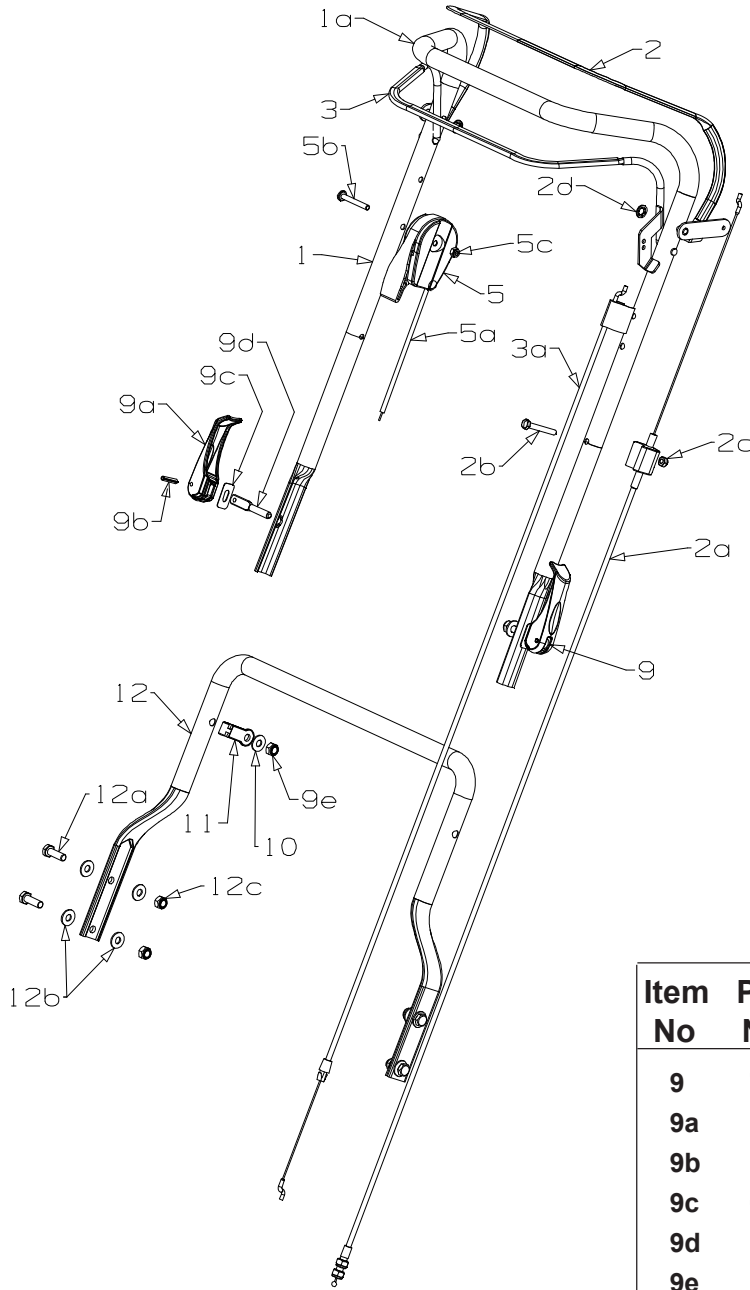

Item No	Part No	Description	Qty
1/1a	773155	Handle & Sleeve,Upt R/MWR	1
2	982161	Bail Arm Assy, SP	1
2a	031990	Cable-Clutch, Reel Mower	1
2b	503558	Screw-Set, M6 x 45	1
2c	501764	Nut-M6 Nyloc	1
2d	501365	Clip- Starlock, 5/16"	2
3	981740	Bail Arm Assy, OPC	1
3a	031878	Cable- Eng, OPC Reel Mower	1
5/5a	583458	Control- Throttle,Hsng Wscn	1
5b	503604	*Screw, Pan M6x45	1
5c	501764	*Nut, M6 Nylocx 6 Thck	1

Item No	Part No	Description	Qty
9	779755	Cam Lock Assembly	2
9a	582419	Lever- Handle, Locking	1
9b	503369	Pin, Tension 5.0 x25	1
9c	016777	Washer Slipper	1
9d	583041	Stud Handle Lock 61mm	1
9e	501793	Nut M8 Hex Nylocx Thck	1
10	501606	Washer, Flat 8x19x1.6	2
11	581527	Retainer- Clutch Cable	1
12	031849	Handle-Lower, 500	1
12a	501597	Screw, Set M8x20	4
12b	501606	Washer, Flat 8x19x1.6	8
12c	501793	Nut, M8 Nylocx 8 Thick	4



Clutch Assembly B&S and Honda

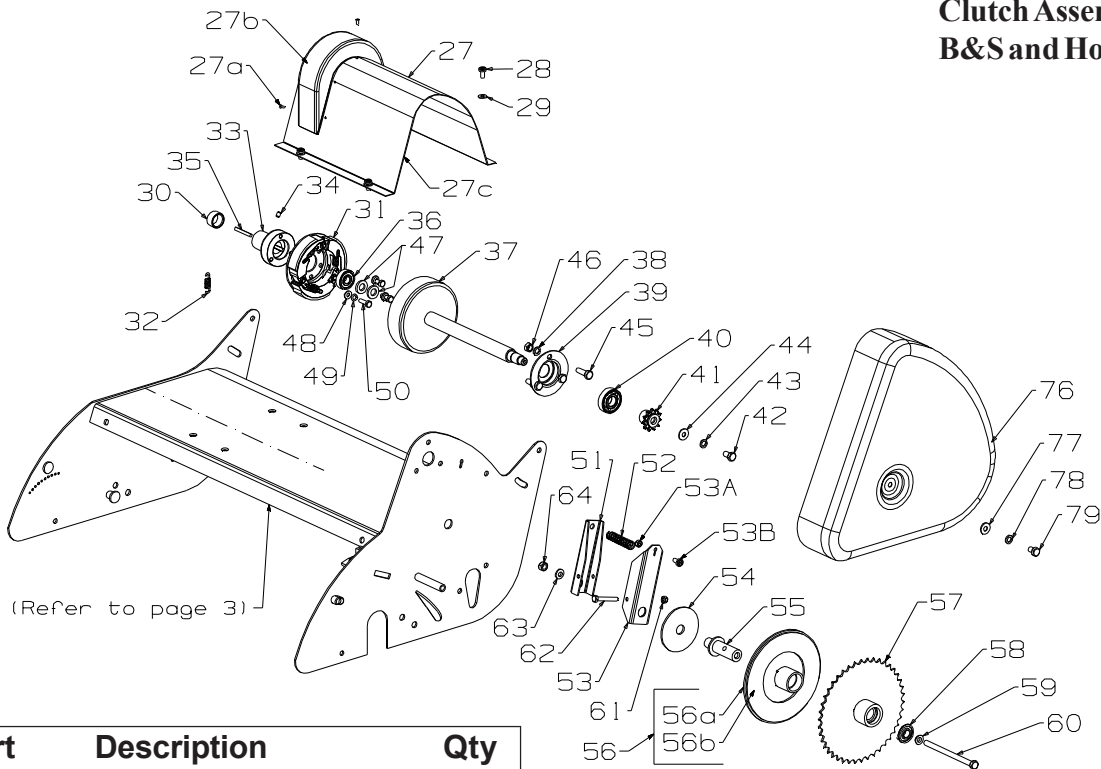

Item No	Part No	Description	Qty	Item No	Part No	Description	Qty
27	031909	Cover- Trans,500/660 EU GRN	1	50	503223	Screw, Set M6x16 HT8.8	3
27a	503429	*Rivet Pop 3.2 x4.8 73 AS4-3	4	51	031831	Lever- Clutch	1
27b	031907	*Cover Trans Moulded	1	52	031845	Spring- Clutch	1
28	503591	Screw, Set M6x12	4	53	031830	Lever Carrier- Clutch	1
29	501703	Washer, Flt 6x14x1.2	4	53a	501764	Nut-M6 Nyloc	1
30	031958	Spacer- Drive Shaft, 13mm	1	53b	503591	Screw-Pan M6 x 12	1
31	031912	Clutch- Drive Assy	1	54	031843	Washer. FLT 16.5x75x3.0	1
32	(005634)	Clutch Spring	3	55	031840	Post- Clutch	1
33	031913	Boss- Clutch, 19 Dia (536012 Key)	1	56	(031988)	Sprocket-11T, Clutch Disk	1
33	031914	Boss- Clutch, 20 Dia (536178 Key)	1	56a	031986	Sprocket- Clutch Plate Assy	1
34	501719	Screw, Grb M6x8	2	56b	031987	Liner- Clutch Face Cork	1
35	536178	Key- Cutter 3/16"SQx24	1	57	031963	Sprocket- 42T, Plate & Boss Assy	1
35	536012	Key- Engine 3/16"SQx38	1	58	503901	Bearing, Ball 12x28x8 6001 2RSH	1
36	501213	Bearing, Ball 12x32x10 6201 2RS	1	59	031965	Washer- Centralizing Brass	1
37	031587	Drum Assy, Clutch 500/660	1	60	503938	Bolt, M8x120 Hex	1
38	503747	Washer, Spg 8	3	61	501764	Nut, M6 Nyloc 6 Thck	1
39	002834	Housing- Bearing	1	62	580160	Screw, Set M6x50 Hex	1
40	503273	Bearing-Ball 17x40x12 6203 2S	1	63	031842	Washer, Thrust	1
41	002818	Sprocket- 11T, Drive	1	64	501793	Nut, M8 Hex Nyloc 8 Thck	1
42	501715	Screw, Set M8x15 1mm Pitch	1	76	031585	Cover - Chaincase- Green	1
43	503747	Washer, Spg 8	1	77	501606	Washer, Flt 8x19x1.6	1
44	501606	Washer, Flt 8x18x1.6	1	78	503747	Washer, Spg 8	1
45	501597	Screw, Set M8x20 Hex	3	79	501863	Screw Set, M8x12	1
46	501602	Nut, M8 Hex	3				
47	006028	Washer, Flt 12x22x3.0	2				
48	501703	Washer, Flt 6x14x1.2	3				
49	500201	Washer, Spg 6	3				



Rear Roller Assembly Painted

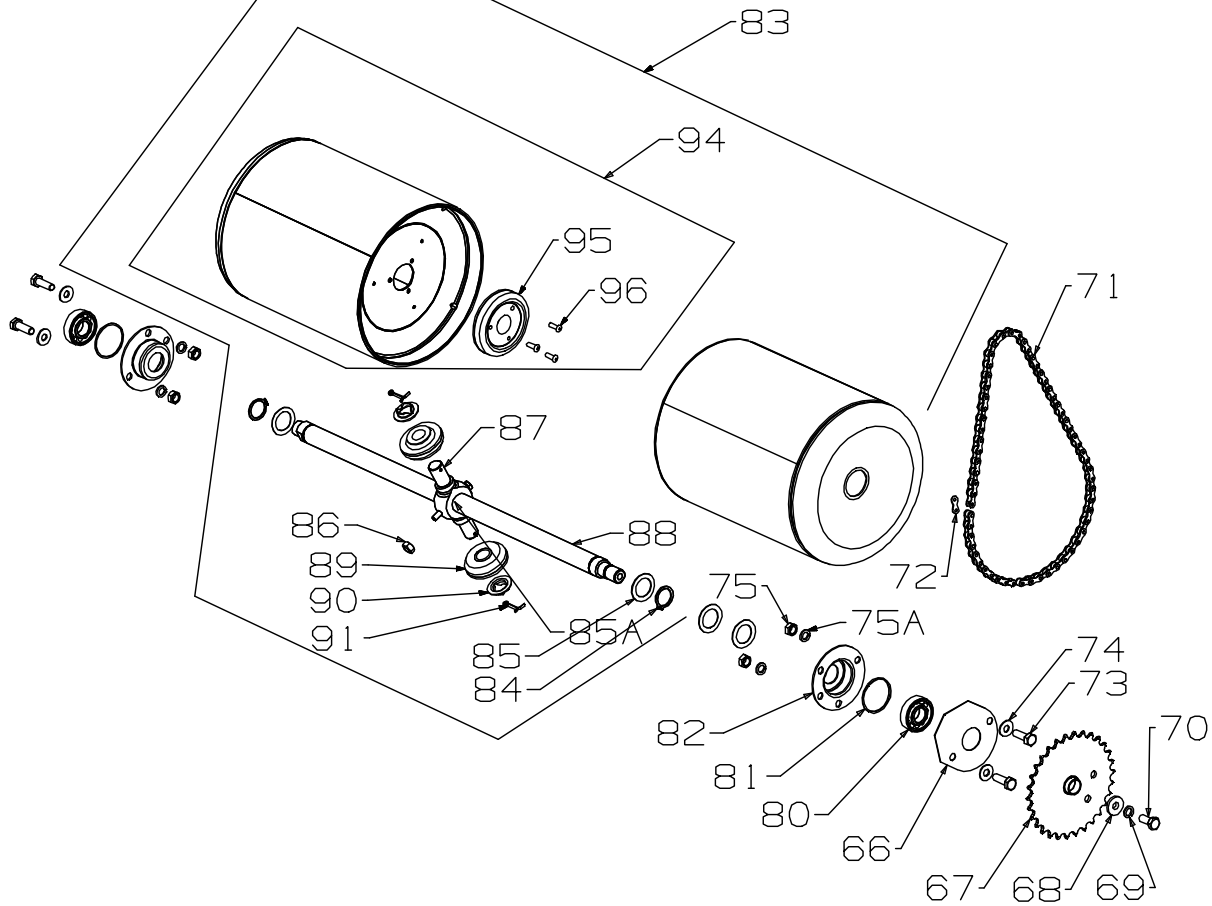

Item No	Part No	Description	Qty	Item No	Part No	Description	Qty
66	002618	Plate- Seal, Bearing	1	84	*007260	Circlip- 7/8" ext	2
67	002604	Sprocket & Boss Assy, Rear Roller	1	85	*002732	Washer-Flt, 22 x 40 x 2	2
68	503872	Washer, Flt 8x20x3.0	1	85a	*567292	Bolt-Hex M6 x 55 HT 8.8	
69	503747	Washer, Spg 8	1	86	*501764	Nut, M6 Hex Nyloc	1
70	501717	Screw, Set M8x20 1mm Pitch	1	87	*008943	Carrier-Bevel Pinion	1
71	004929	Chain, 3/16" x 1/2, 40P	1	88	*008947	Spindle-Rear Roller 500	1
72	(731971)	Link, Chain 1/2	1	89	*002708	Pinion-Bevel, 14T	2
73	501597	Screw, Set M8x20	4	90	*008944	Collar	2
74	501606	Washer, Flt 8x19x1.6	4	91	*007473	Split Pin, 3.0dia x 30	2
75	501602	Nut, M8 Hex	4				
75a	503747	Washer, Spg 8	4	94	031956	Roller-Rear,Half Assy (Painted)	2
80	503273	Bearing-Ball 17x40x12 6203 2S	2	95	*002707	Gear-Bevel, 24t	1
81	(004292)	Ring-Bearing Housing	2	96	*503399	Rivet-Pop, 4.8 x 13 73 SS 6-8	3
82	(000409)	Housing-Bearing	2				
83	031918	Roller Assy, Comp (Painted)	1				

* Items are included in assemblies 83